

ONE - HANDRAIL - 3800HR

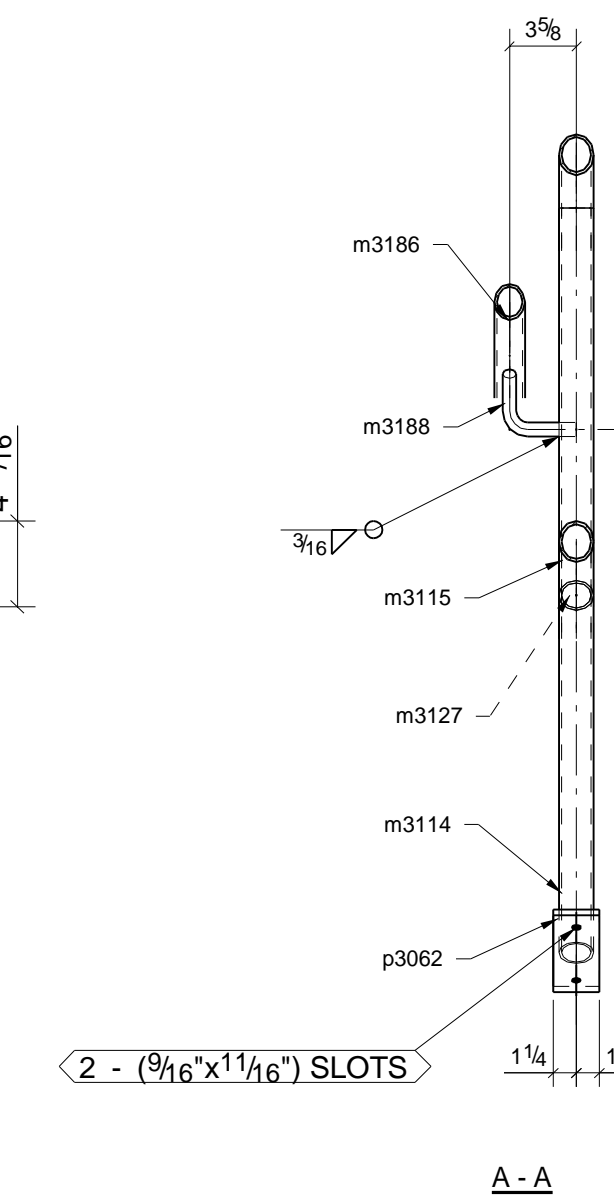
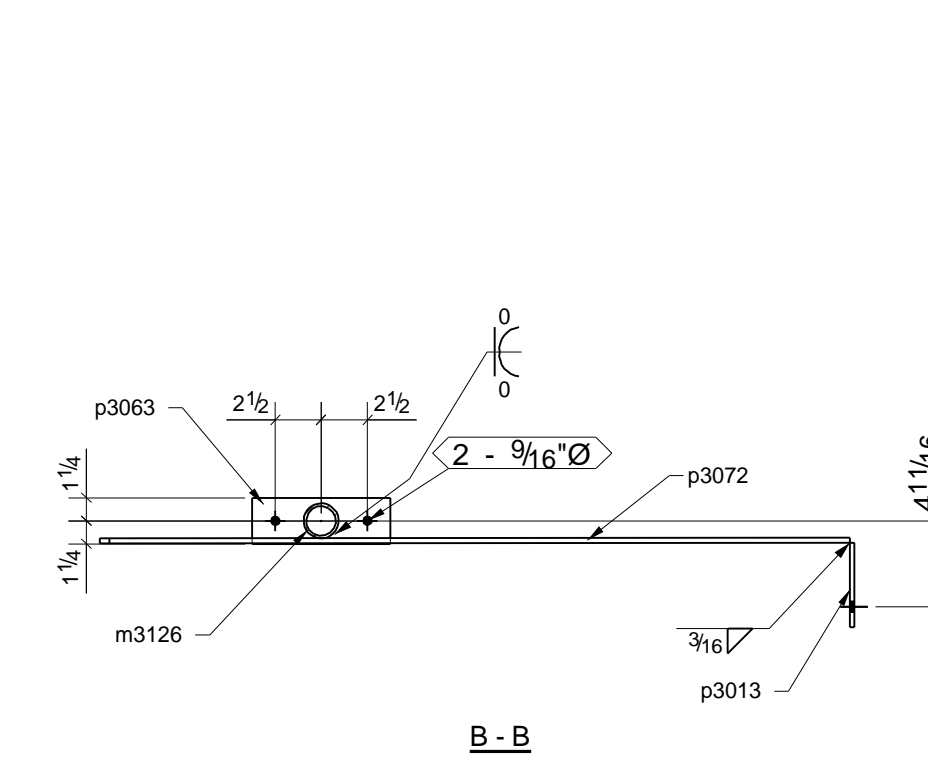

BILL OF MATERIAL

Qty Ea.	Qty Tot	Piece Mark	Description	Length	Weight Total	Remarks	Adv Mill #	Steel Grade
	1	3800HR	HANDRAIL					
1	1		PIPE1-1/2STD	8'-8 1/16"	22			A53_GR.B
2	2	m3114	PIPE1-1/2STD	3'-4 15/16"	17			A53_GR.B
1	1	m3115	PIPE1-1/2STD	3'-9 3/16"	10			A53_GR.B
1	1	m3126	PIPE1-1/2STD	3'-6 7/8"	9			A53_GR.B
1	1	m3127	PIPE1-1/2STD	2'-9 1/8"	7			A53_GR.B
1	1	m3130	PIPE1-1/2STD	3'-9 7/16"	10			A53_GR.B
2	2	m3177	PIPE1-1/2STD	0'-6 15/16"	3			A53_GR.B
1	1	m3183	PIPE1-1/2STD	3'-7 1/16"	9			A53_GR.B
1	1	m3184	PIPE1-1/2STD	1'-0 1/4"	3			A53_GR.B
1	1	m3185	PIPE1-1/2STD	2'-6 13/16"	7			A53_GR.B
1	1	m3186	PIPE1-1/4STD	10'-2 1/8"	22			A53_GR.B
2	2	m3188	RB3/4"	0'-5 7/8"	1			A36
1	1	p3013	FB1/4"X4"	0'-4 5/8"	1			A36
2	2	p3062	FB3/8"X2 1/2"	0'-8"	4			A572-GR.50
1	1	p3063	FB3/8"X2 1/2"	0'-7 1/2"	2			A572-GR.50
1	1	p3072	FB1/4"X4"	3'-4 11/16"	12			A36
6			1/2"Ø A325N BOLT	0'-2"		Site	C/W BEV. W	

- NOTES:
- POWDER COAT SAFETY YELLOW
 - FIT RAILS, TYP.
 - GRIND SMOOTH ALL SHARP CORNERS & BURRS.

REF	E3003	PROJECT NAME	COVANTA ESSEX AREA 3
MATERIAL	AS NOTED	LOCATION	183 RAYMOND BVLD, NEWARK, NJ
HOLES	AS NOTED	CONTRACTOR	COVANTA ESSEX CO.
BOLTS	AS NOTED, GALVANIZED	DESCRIPTION	HANDRAIL
ALL COPES AND BLOCKS TO HAVE 1/2 RAD. UN		PHASE:	3
WELDS E70XX		DATE	05/10/2013
SURF. PREP. See Covanta Energy Spec SA-550		CHECKED BY	EDG
PAINT NOTE See Covanta Energy Spec SA-550		DATE	05/10/2013

DATE	NO.	DESCRIPTION	BY
ORACLE STEEL CONSULTANTS LTD			
DRAWN BY	EHS	CHECKED BY	EDG
JOB No.	13-0794-B		
DRG No.	3800HR		