

ONE - BEAM- 1132B

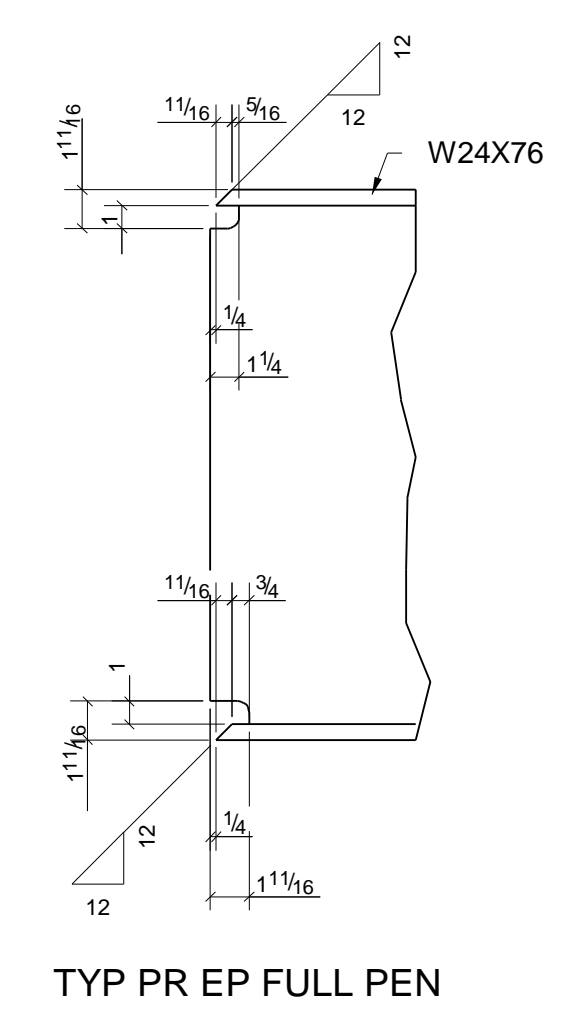

TYP PR EP FULL PEN

BILL OF MATERIAL

Qty	Qty	Pi	Des	Length	Wei	Remar	Adv	St
E a.	Tot	Mark	c r i p t i o n		g h t	k s	M ill#	el
					T o t a l			G r a d e
1	1	1	3 2 B BEAM					
1	1		W24X76	23'- 5 3/4"	17 90		11 32B	A992
4	4	a1 0 0 4	L4X4X3/8	0'- 8 1/2"	28			A36
1	1	p1 0 0 6	PL1/2" X12 15/16"	2'- 1 9/16"	44			A36
1	1	p1 0 1 0	PL1/2" X12 7/8"	2'- 2 7/16"	45			A36
1	1	p1 0 2 8	FB1/2" X6"	0'- 7 5/8"	6			A36
1	1	p1 0 3 1	FB1/2" X6"	0'- 8 7/16"	7			A36
1	1	p1 0 3 4	FB1/2" X6"	0'- 8 7/16"	7			A36
1	1	p1 0 3 7	FB1/2" X6"	0'- 7 5/8"	6			A36
3			3/4"Ø A325N_TC-DTA325TCB	0'- 2"		Site		GALVANI ZE
21			3/4"Ø A325N_TC BOLT	0'- 2"		Site		GALVANI ZE

REF	E 1 0 0 2	PROJ ECT NAME	
MATERI A L	A 9 9 2	LOCAT I O N	
HOLE S	1 3 / 1 6"	UNO	
WELDS	E 7 0 XX (SEAL W E L D S T Y P)	C O N T R A C T O R	
SURF. PREP.	S S P C - S P 8	DESCR I P T I O N	
P A I N T	NOTE HOT-DI P GALVANI ZE	SEQUENCE	

11 / 2 1 / 1 1	Issued For Fabrication	
09 / 3 0 / 2 0 1 1	Issued For Approval	
D A T E	N O.	D E S C R I P T I O N

<p>Oracle Steel Consultants Ltd. www.oraclesteel.com.</p>		
DRAW N BY	CHECKED BY	JOB No.
MM	EDG	11-0607
DATE	DATE	DRG No.
09 / 2 6 / 2 0 1 1	09 / 3 0 / 2 0 1 1	1132B